

ANALOX O2 PORTABLE OPERATORS MANUAL

Analox Sensor Technology Ltd
15 Ellerbeck Court
Stokesley Business Park
Stokesley
N. Yorks
TS9 5JY

Tel: +44 (0)1642 711400
Fax: +44 (0)1642 713900
Email: info@analox.net

CONTENTS

1.0	Introduction.....	3
2.0	Controls	4
3.0	Air Calibration	5
4.0	Pure Oxygen Calibration.....	6
5.0	Operation	7
6.0	Troubleshooting.....	9
7.0	Maintenance.....	10
8.0	Care of the O2 Portable.....	11
9.0	Safety	12
10.0	Warranty Information.....	14
11.0	Specifications.....	16
12.0	Spares.....	17
13.0	Disposal.....	18

1.0 Introduction

- 1.1 The O2 Portable Oxygen Analyser is designed to measure Oxygen levels in the range 0.1-100% O2.
- 1.2 The analyser should be used for cylinder oxygen level verification or for monitoring a gas mixing panel but should not be used for both. If the analyser is used for measuring the oxygen level in the output from a mixing panel, another O2 Portable should be used for cylinder verification purposes.
- 1.3 The O2 Portable has a large digital display and operates from an internal temperature compensated minimum 3 year life electrochemical oxygen sensor. Power is provided by a 9V, 4000 hour life battery giving up to 3 year operation before replacement is necessary.
- 1.4 The O2 Portable is a water resistant drop resistant totally self contained unit designed specifically for all the diving industry -Sport (NITROX), Commercial and Military - where hostile environmental conditions are the norm not the exception.
- 1.5 Your O2 Portable is supplied ready to use. To protect the oxygen sensor from dirt and dust it is fitted with an adhesive seal, which must be removed before use. On receipt of the unit, please check for damage. If there is any damage, contact your supplier.

WARNING

**It is important that
these instructions are read
before the analyser is used!**

2.0 Controls

- 2.1 The analyser is fitted with an on/off switch located on the front of the unit. Push the switch up or down to turn the unit on and return it to the central position to turn it off. When it is switched on the analyser's display will show an oxygen reading but do not use before calibration (see section 3.0).
- 2.2 The low battery warning is a battery symbol in the corner of the display. When present, change the batteries before using the instrument (see section 8.0 Maintenance).
- 2.3 A waterproof calibration knob is located on the front. Turn it fully from left to right and then fully left, the reading should increase and then decrease. (If the reading does not change see section 8.0 Maintenance).

WARNING
Do NOT use when
the LOW BATTERY symbol is on!
ANALOX O2 PORTABLE OXYGEN ANALYSER

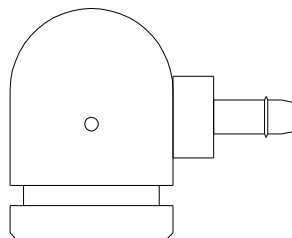
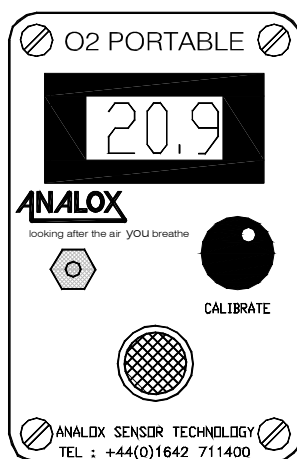

DII Adaptor

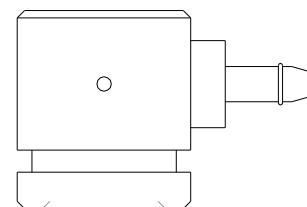

Standard Adaptor

3.0 Air Calibration

- 3.1 Air calibration is essential before every use and is performed as follows.
- 3.2 Ensure that the sensor seal and any flow adaptors are removed and the reading on the display has stabilised.
- 3.3 Expose the analyser to clean air for two minutes and adjust the calibration knob until the display reads the correct value using the humidity chart (you can find the humidity chart on the inside of the back cover). If this is not possible refer to paragraph 3.4 or to section 8.0 Maintenance.
- 3.4 It is possible that at very high altitude normal calibration is not achievable. In this event you must ascertain the actual pressure in BAR and multiply the atmospheric oxygen percent (20.9%) by this pressure and set the reading during calibration to the calculated level (this is the surface equivalent oxygen percentage). When you measure the level of oxygen in the sample you must divide the reading by the same atmospheric pressure value to obtain the true percentage of Oxygen in your sample.

For Example: At an atmospheric pressure of 0.8 BAR the surface equivalent oxygen percentage is $20.9\% \times 0.8 = 16.7\%O_2$ Surface Equivalent. If the reading you then obtain from your sample is 32.0% you must divide this by 0.8 to obtain the true Oxygen percentage, $32.0/0.8 = 40.0\%O_2$ True Percentage.

- 3.5 The analyser is now ready for oxygen measurement.

WARNING

**The analyser is sensitive to Oxygen partial pressure.
Calibration must always be carried out at the same
atmospheric pressure as Oxygen measurement.**

- 4.0 Pure Oxygen calibration for measuring oxygen purity up to 100%.**
- 4.1 Connect 100% bottled oxygen (certified) to the flow adaptor and adjust the flowrate to between 0.5 and 1.0 litre per minute.
- 4.2 Allow the reading to settle.
- 4.3 Expose to atmosphere, the reading should display +/- 0.4 of corrected humidity value i.e. between 20.5 and 21.3

5.0 Operation

5.1 Standard O2 Flow Adaptor

- 5.11 Connect the standard flow adaptor to the sensor and pass the gas to be analysed over the sensor slowly at 1 to 2 litres per minute until the reading stabilizes. There should be no significant rapid change in reading when the gas flow is stopped as this indicates that the flow was too high and the sensor pressurized. If a rapid change is seen within 2 or 3 seconds of the gas being turned off, repeat at a lower flow.
- 5.12 When a stable reading is observed with the gas flow on and 2 to 3 seconds after being turned off, take the reading.
- 5.13 Note that after a few seconds of the gas flow being stopped the reading will begin to change towards the level in the surrounding air of 20.9% O₂ you should therefore take the reading while flow is on.

WARNING!

Do not pressurise the sensor as inaccurate readings will result.

Analox MIO2SK Sample Kit

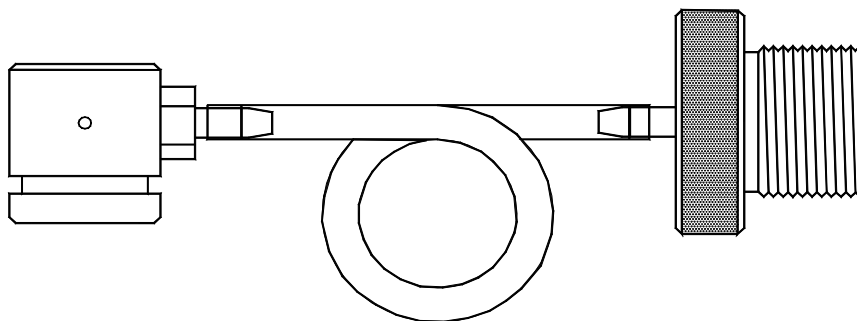

5.2 DII Flow Adaptor

- 5.21 The Analox O2 Portable comes complete with the unique DII adaptor which allows to you to directly apply the analyser to the outlet on your nitrox tank.
- 5.22 Ensure the sensor seal is removed. Connect the DII adaptor to the analyser by pushing the adaptor over the sensor turret. The O ring on the sensor should ensure a comfortable fit.
- 5.23 Hold the DII adaptor firmly against the cylinder outlet facing you. Very slowly open the pillar valve until gas can just be heard hissing through the flow adaptor.

WARNING
Open cylinder valve
EXTREMELY CAREFULLY

- 5.24 Close the pillar valve after fifteen seconds when a stable reading is observed on the O2 Portable.
- If in doubt repeat the procedure taking care to ensure a very low gas flow.
- 5.25 Note that after a few seconds of the gas flow being stopped the reading will begin to change towards the level in the surrounding air of 20.9% O2 you should therefore take the reading while flow is ON.

WARNING
Do not pressurise the sensor
as inaccurate readings will result.

6.0 Troubleshooting

SYMPTOM	REASON	SOLUTION
Battery symbol	Low battery	Change battery
No display	Switched off Bad connection	Switch on Check display connection Check battery connection
Zero reading	Sensor disconnected Sensor expired	Check connection Change sensor
Reading erratic	Pressure on sensor Radio transmission Sensor old or faulty Condensation on sensor	Check flow Move unit away Change sensor Dry sensor face
Reading does not change when calibration knob is turned	Faulty connections Sensor failure	Check connections Change sensor
Display segments missing	Display faulty	Return to dealer
Will not calibrate	Sensor faulty Sensor not in air High altitude	Change sensor Check flow adapter Calculate percent equivalent = $20.9\% \times \text{bar}$
Reading drifts	Rapid temperature change	Do not move analyser from one temperature to another immediately before use

7.0 Maintenance

7.1 Battery replacement.

- a) Remove the 4 screws located at each corner of the unit and carefully lift the lid.
- b) Slide the battery out of its spring bracket and disconnect the lead.
- c) Connect the lead to the new battery and slide the battery behind the spring bracket.
- d) Replace the lid carefully and screw down taking care that the sensor locates properly.
- e) Ensure that you do not trap any wires.

7.2 Sensor replacement.

- a) Replacement sensor part number: 9100-9212-5AD
- b) Remove the 4 screws located at each corner of the unit and carefully lift the lid.
- c) Remove the flow adapter if fitted and slide the sensor out of the lid.
- d) Disconnect the in line sensor connector.
- e) Dispose of the old sensor according to local regulations for Lead and Potassium Hydroxide solution.
- f) Remove the new sensor from its bag and check it for leaks, connect to the inline connector and slide through the lid.
- g) Replace the lid carefully and screw down taking care that the sensor locates properly. Ensure that you do not trap any wires.

8.0 Care Of The O2 Portable

- 8.1 Although designed to be water resistant the O2 Portable should not be intentionally immersed in liquid or left outside unprotected.
- 8.2 The O2 Portable is built to resist the effects of day to day shocks and drops but remember it is a precision oxygen analyser and should be looked after carefully to give long trouble free service.
- 8.3 To clean the O2 Portable use a damp soft cloth.
- 8.4 Protect the O2 Portable from long periods of direct sunlight and do not subject it to high or low temperature extremes.
- 8.5 The sensor in the O2 Portable is an electrochemical device and contains a caustic electrolyte. Always check to make sure that it is not leaking and do not allow it onto any part of your body or clothing. In the event that you do come into contact with the electrolyte wash the contaminated part with copious amounts of water -see Safety Information.

ANALOX 9212 OXYGEN SENSOR

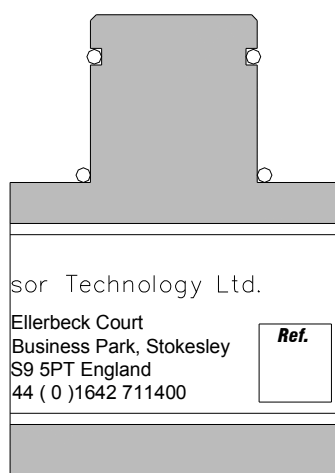

WARNING
**If after handling the sensor
your fingers or other part of your
body feels slippery or stings
wash with a lot of water.**

**If stinging persists get medical
attention!**

9.0 Safety Information O2 Portable

9.1 When the life of the battery has expired it should be disposed of safely in accordance with local regulations.

9.2 When the life of the sensor has expired or it is leaking or otherwise damaged it must be disposed of safely in accordance with local regulations.

9.3 The sensor contains KOH Potassium Hydroxide solution which is hazardous and can have the following effects:

Skin	Potassium Hydroxide is corrosive – skin contact could result in a chemical burn.
Ingestion	Can be harmful or FATAL if swallowed.
Eye	Contact can result in the permanent loss of sight.

First Aid Procedures.

Skin	Wash the affected part with a lot of water and remove contaminated clothing. If stinging persists get medical attention.
Ingestion	Drink a lot of fresh water. Do not induce vomiting. Get medical attention.
Eye	Wash with a lot of water for at least 15 minutes and get medical help immediately.

9.4 Sensor Handling Information.

O2 Portable oxygen sensors are supplied normally in sealed bags. Before the bag is opened check that the sensor has not leaked. The sensors are themselves sealed and do not under normal circumstances present a health hazard however if leakage of the Potassium Hydroxide electrolyte has occurred use rubber gloves and wear chemical splash goggles to handle and clean up. Rinse contaminated surfaces with water.

10.0

We provide the following Warranties for the Analox O2 Portable:

A 3 year graded sensor warranty.

A 3 year electronics warranty.

In both cases the Warranty period runs from the date of our Invoice.

We warrant that the equipment will be free from defects in workmanship and materials.

The Warranty does not extend to and we will not be liable for defects caused by the effects of normal wear and tear, erosion, corrosion, fire, explosion, misuse, use in any context or application for which the equipment is not designed or recommended, or unauthorised modification.

Following a valid Warranty claim in accordance with the above, the equipment, upon return to us, would be repaired or replaced without cost or charge but in our discretion we may elect instead to provide to you which ever is the lesser of the cost of replacement or a refund of net purchase price paid as per our Invoice on initial purchase from us. We shall have no liability for losses, damages, costs or delays whatsoever. We shall have no liability for any incidental or consequential losses or damages. All express or implied warranties as to satisfactory or merchantable quality, fitness for a particular or general purpose or otherwise are excluded and no such Warranties are made or

provided, save as set out in this Clause 7.

In order to effectively notify a Warranty claim, the claim with all relevant information and documentation should be sent in writing to:

Analox Sensor Technology Limited
15 Ellerbeck Court
Stokesley Business Park
Stokesley
North Yorkshire
TS9 5PT

Or by e-mail to : info@analox.net

Or by Fax to : +44 1642 713900

We reserve the right to require from you proof of dispatch to us of the notification of Warranty claim by any of the above alternative means.

The equipment should not be sent to us without our prior written authority. All shipping and Insurance costs of returned equipment are to be born by you and at your risk. All returned items must be properly and sufficiently packed.

11.0 Specifications

Range	0.1 -100.0% Oxygen
Typical Accuracy	+/-1% of reading over range 0-50% when calibrated on air in accordance with the manual. +/-2% of reading over range 0-100% when calibrated on certified pure Oxygen in accordance with the manual.
Resolution	0.1% Oxygen
Response time	90% in less than 15 seconds
Sensor Type	Analox 9212-5AD
Sensor Life	More than 36 months in air. 36 month graded guarantee in air.
Battery	9V Alkaline (PP3)
Battery Life	4000 Hours. Upto 36 months intermittent use.
Operating temp	-5 to 50 C
Storage temp.	-5 to 50 C
Pressure	Sensitive to the partial pressure of Oxygen.

12.0 Spares

Your O2 Portable unit is supplied with an Analox Oxygen sensor 9212-5AD, a 9v battery, a standard flow adaptor and 1 high pressure DII adaptor.

You are able to purchase these spares directly from us on Tel: +44 (0)1642 711400, Fax: +44 (0)1642 713900 or you can buy them directly from our website www.analox.net.

9100-9212-5AD Spare oxygen cell for the Analox O2 Portable

8000-0002A High pressure DII adaptor

8000-0007A Standard Flow Adaptor

Visit www.analox.net
Nitrox page, for news and views on nitrox diving.

If you have any comments or queries about the O2 Portable please contact us on Tel: +44 (0)1642 711400 or Fax: +44 (0)1642 713900
Email: info@analox.net or visit our website

www.analox.net

13.0 Disposal

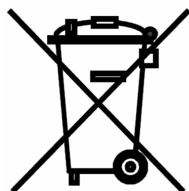

According to WEEE regulation this electronic product can not be placed in household waste bins. Please check local regulations for information on the disposal of electronic products in your area.